



# Assembly Instructions

## Single Tier Locker - Bank of One



# PARTS LIST

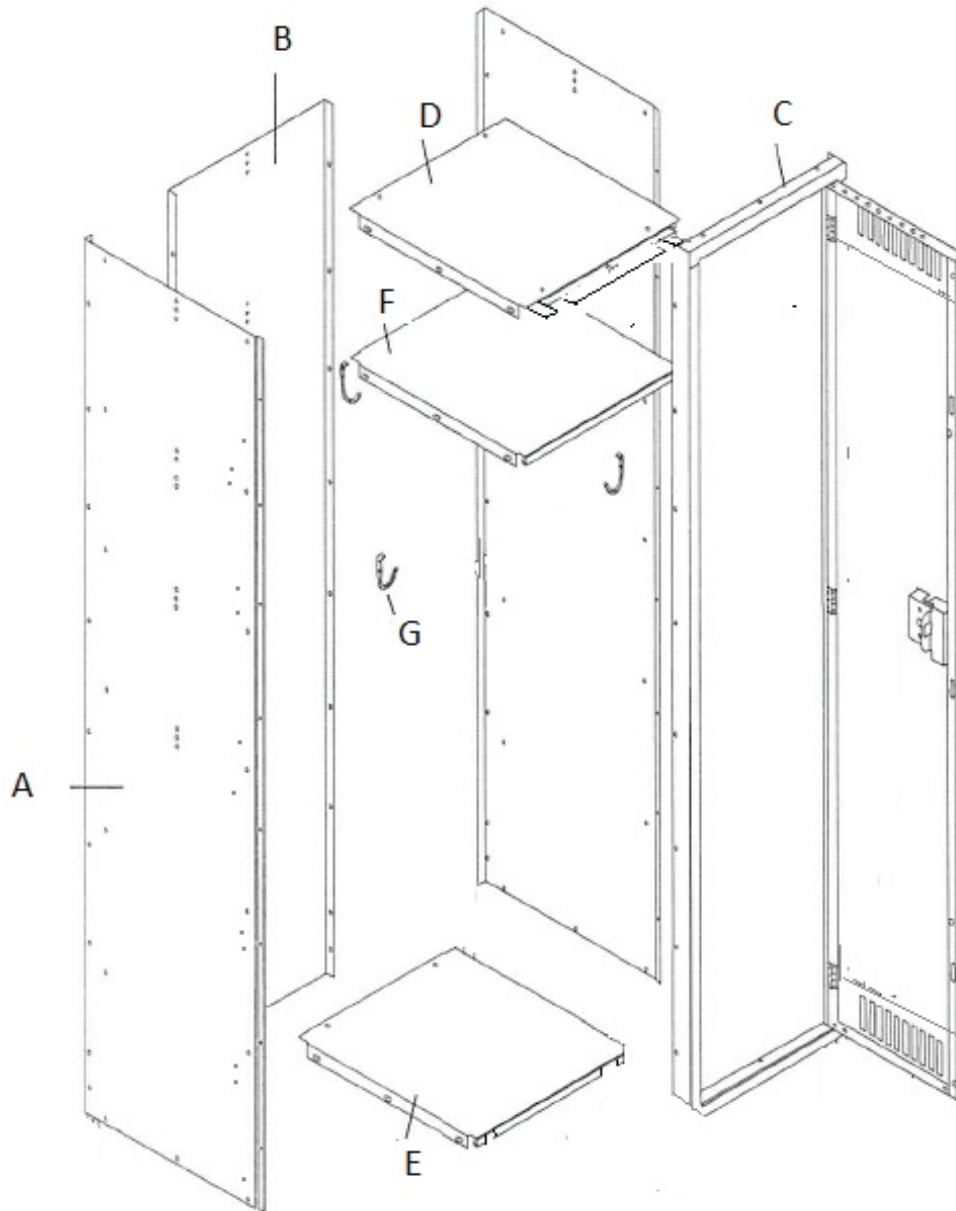

## Bank of 1

	Description	Qty
A	Side Panels	2
B	Back Panel	1
C	Door/Frame Panel	1
D	Top Panel	1
E	Bottom Panel	1
F	Shelf	1
G	Coat Hooks	3

# ASSEMBLY INSTRUCTIONS

**Figure 1**

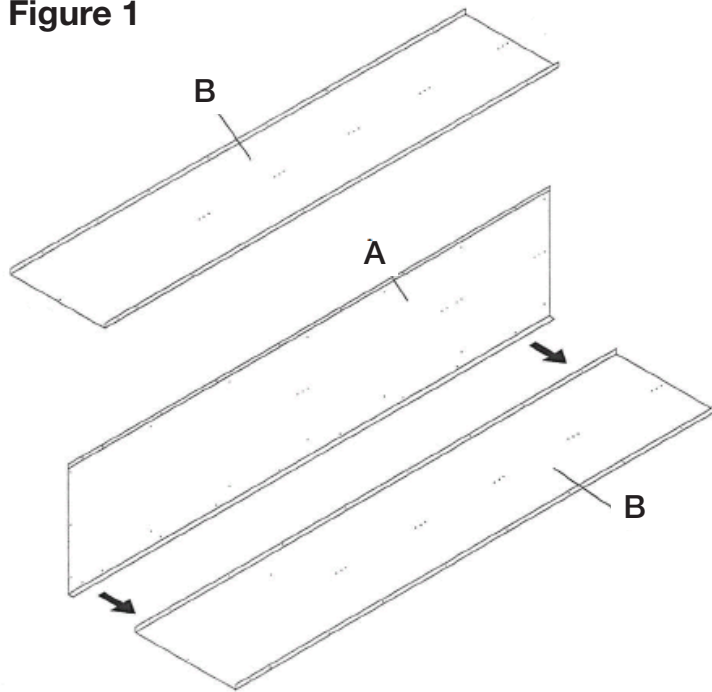

Only tighten bolts with a 3/8" nut driver once the locker is completely assembled.

**1.** Choose one side panel (A) as the left side, both sides are interchangeable and do not have a determined top and bottom.

**2.** Place back panel (B) on a flat surface with flanges facing upward. The back panel does not have a determined top and bottom.

**3.** Bolt the left side panel with the flanges going around the back panel (*Figure 1*) using 10 nuts and bolts, with the nuts on the inside of the locker.

**Figure 2**

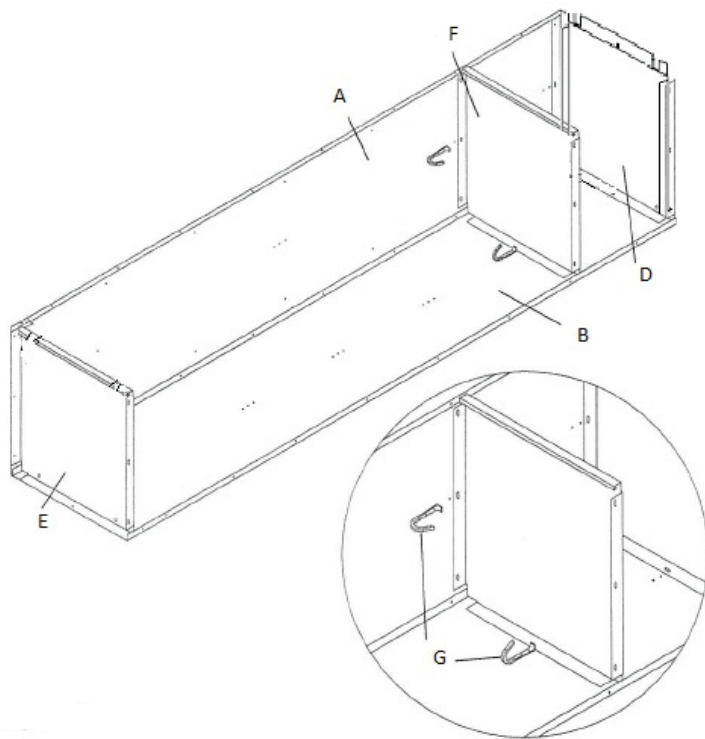

**4.** Bolt the top (D) and bottom (E) panels, and the shelf (F) to the left side and back panels. Next, bolt the coat hooks (G) to the left side and back panels (*Figure 2*).

## ASSEMBLY INSTRUCTIONS

**Figure 3**

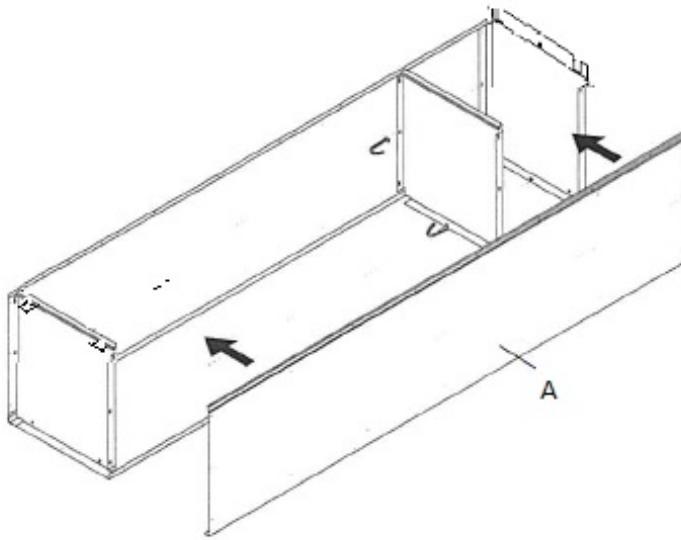

**5.** Bolt the right side panel (A) with the flanges going around the back panel. Bolt the side to the top, bottom and shelf. Also, bolt the third coat hook to the right side panel (*Figure 3*).

**6.** Position the door/frame panel (C) on top of the locker. Bolt to the locker body (*Figure 4*).

**7.** Proceed to tightening each bolt, then standing locker upright to place in desired location.

\*If joining already assembled lockers together, attach units by bolting in the available holes bordering the locker frame.

**Figure 4**

