

KLETON

OUTDOOR - WAGON 24"W X 48"L

MQ170

USER MANUAL



COMPONENTS

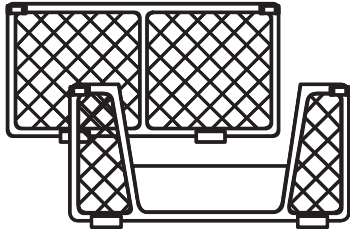

A End Sections

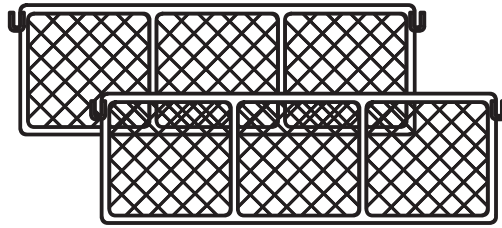

B Side Sections (x2)

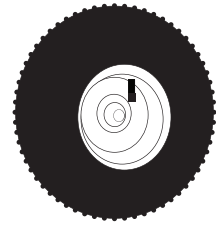

C Pneumatic Wheels (x4)

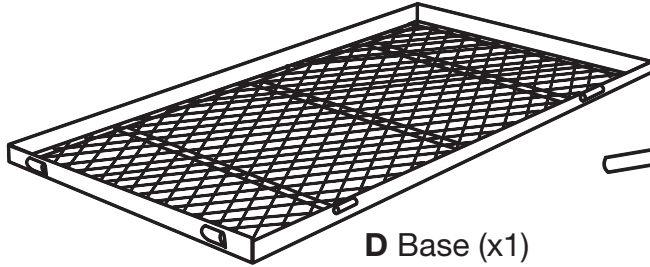

D Base (x1)

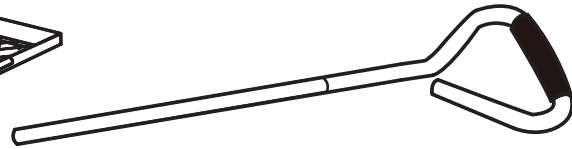

E Handle (x2)

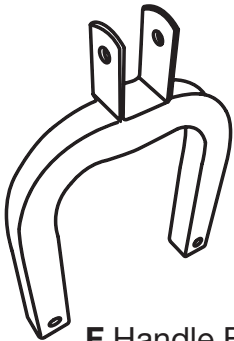

F Handle Bracket (x1)

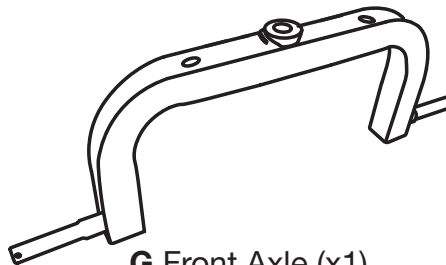

G Front Axle (x1)

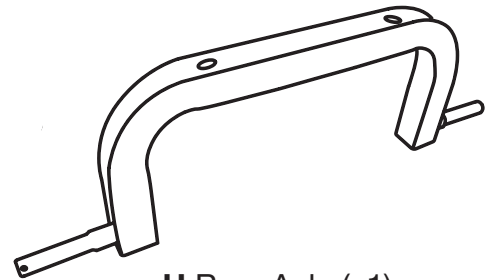

H Rear Axle (x1)



I Hinge (x1)

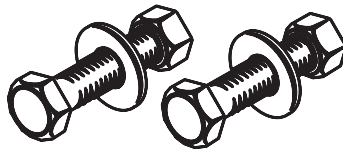

J Bolt/Washer/Nut (x2)



K Nylon Nut (x3)



M Large Washer (x8)



N Small Washer (x3)



O Panel Clip (x10)



P Small R-pins (x6)



Q Cylindrical Pin and Small R-pin (x1)



R Bolt/Washer/Nut (x1)

ASSEMBLY

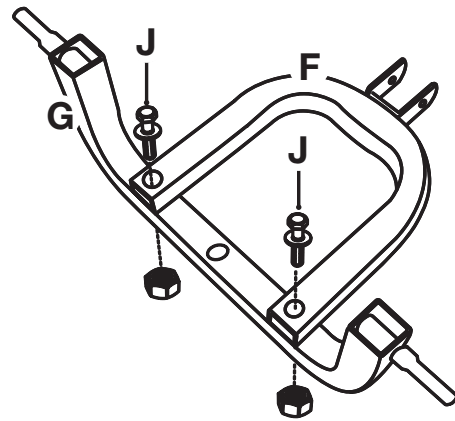

STEP 1: Fix the handle bracket (F) to the Front Axle (G) using the two (J) Bolt/Washer/Nut.

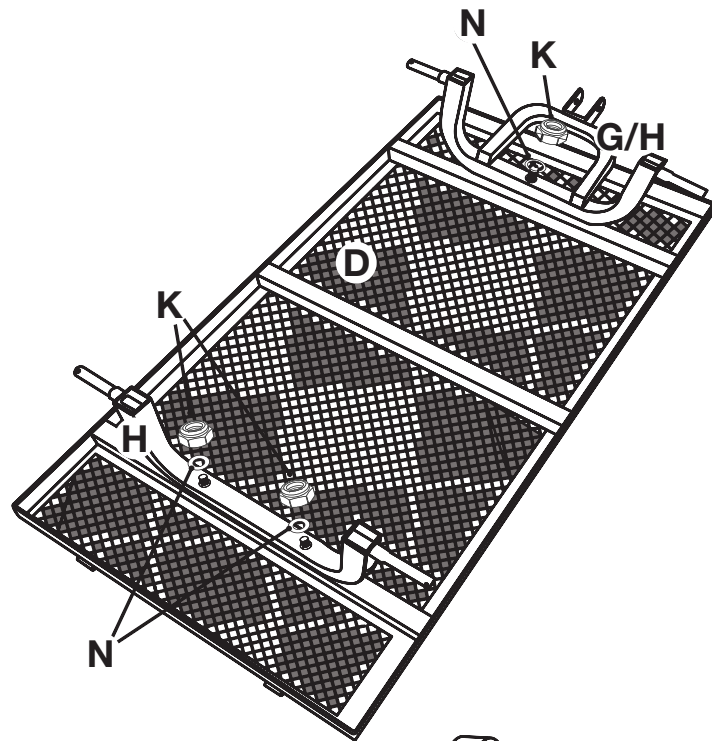

STEP 2: Take the Base (D) and turn upside down so that the protruding bolts are facing upward. Place both axles (G/H) over the bolts, followed by the washers (N) and secure into place using both the Large Nylon Nuts (K) as shown.

STEP 3: Attach the 4 pneumatic wheels (C) to each end of the assembled base followed by a Large Washer (M). Secure into place by threading Small R-pins (P) through each of the holes and bending to secure.

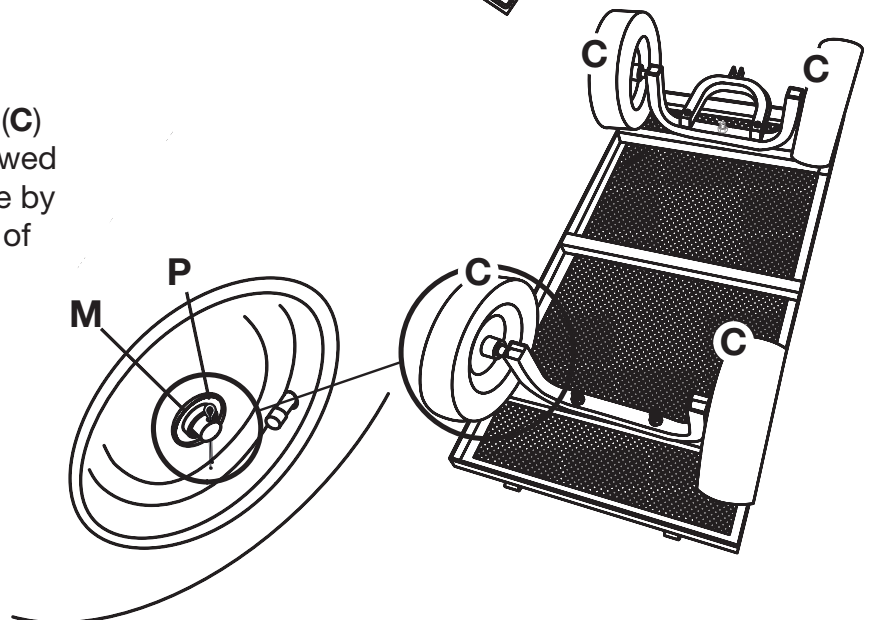

ASSEMBLY

STEP 4: Take the Hinge (I), insert the Handle (E), and align the holes. Take the Handle (E) and Hinge (I), align to the holes on the Handle Bracket (F) and thread through the cylindrical pin and secure into place using the R-pins (Q).

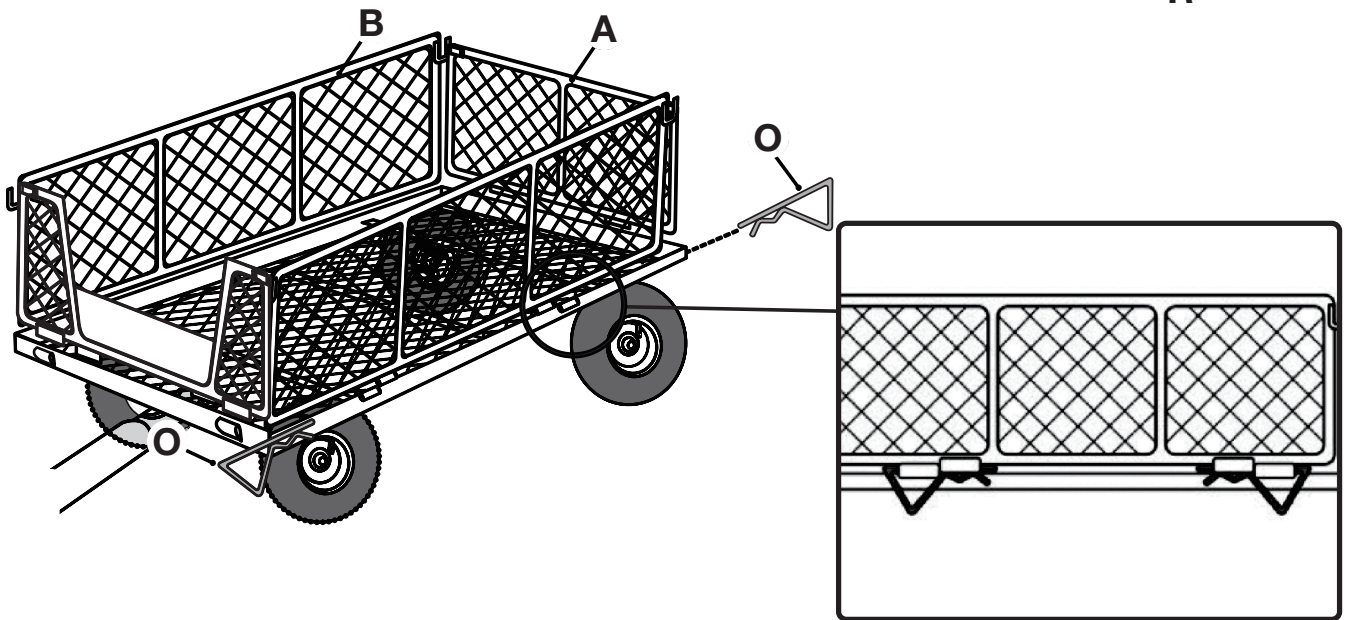
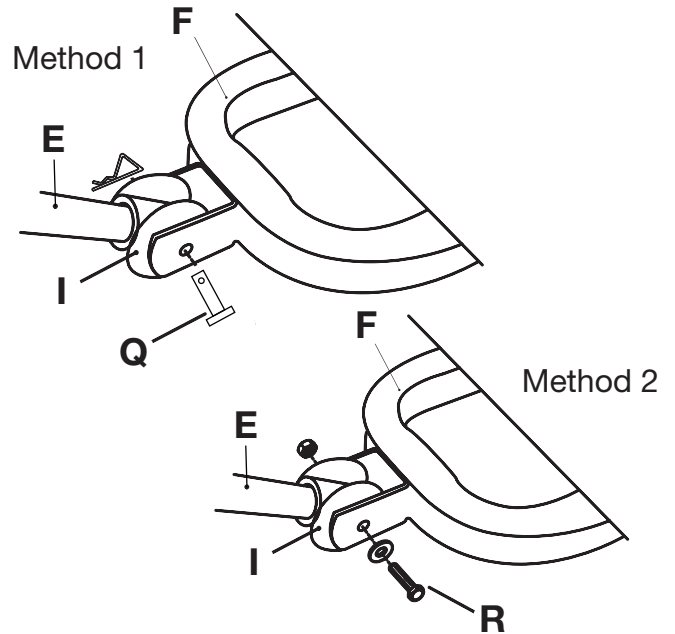

STEP 5: Turn the wagon assembly onto its wheels. Take the Side Sections (B) and the End Sections (A) and secure into place using the R-pins (O).

NOTE: Ensure the brackets are on the outside of the wagon for the Sides and Ends to sit flush.

NOTE: Lift the Locking Handles to align with the slots on the Side Panels. Lower the Locking Handles to secure.

Replacement Parts

Product	Description
MQ186	Replacement Hardware Pack
MQ187	Replacement Wheel "C"
MQ188	Replacement Panel Clips "O"