

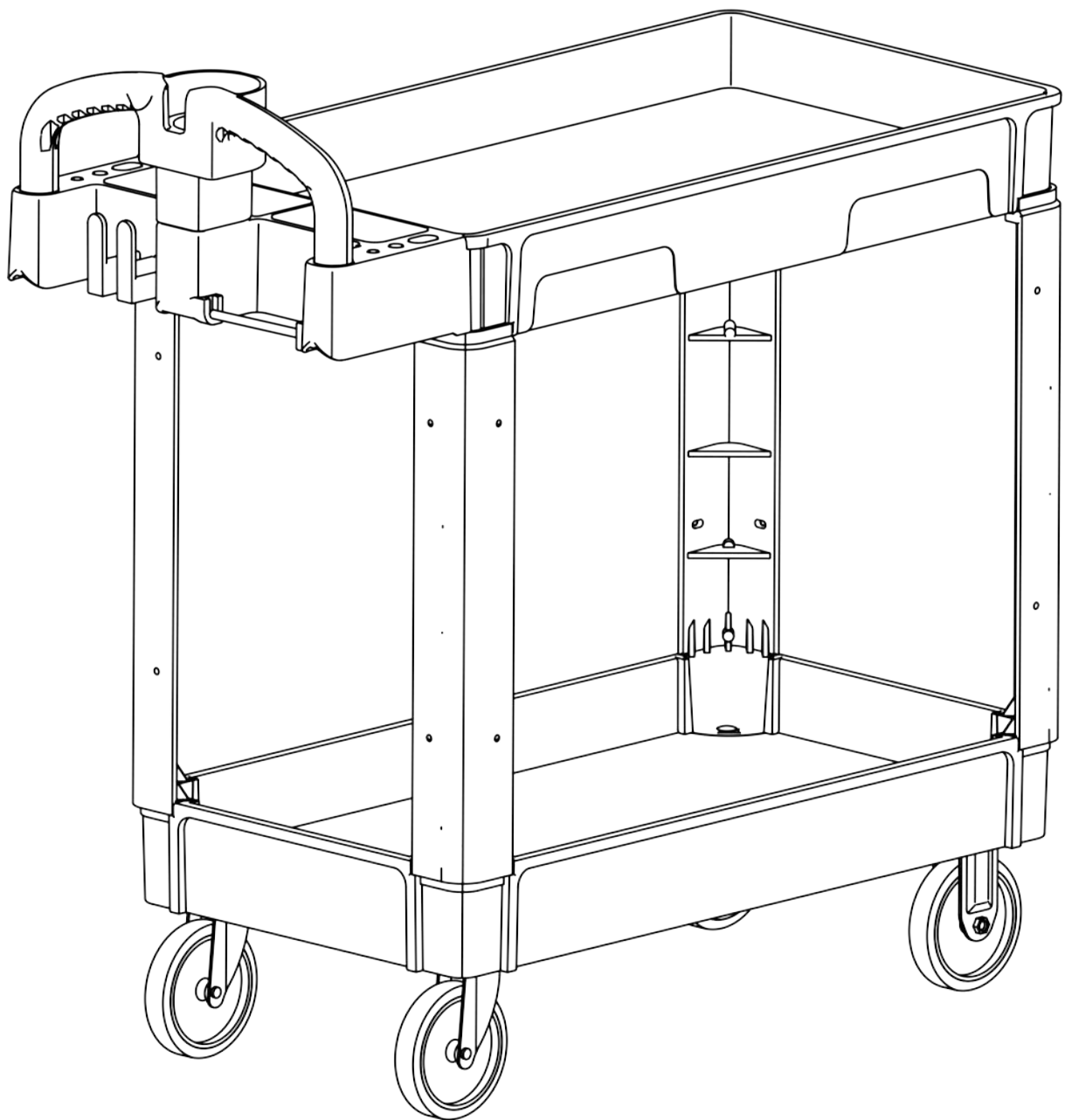



MQ092 - UTILITY CART



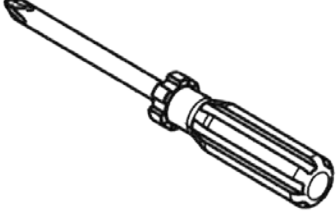

ASSEMBLY INSTRUCTIONS

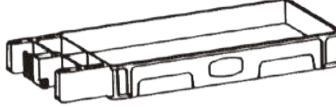
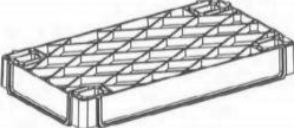
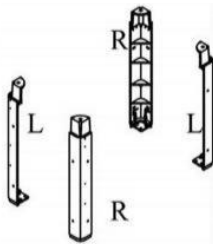
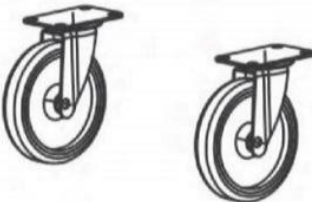

Tools Required For Installation

| | |
|---|---|
| Phillips Screw Driver | Rubber Mallet |
|  |  |

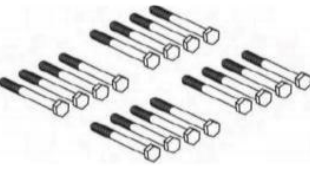
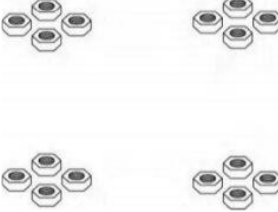
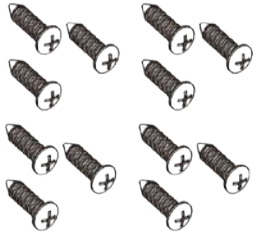
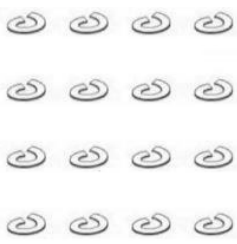
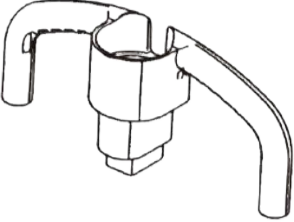
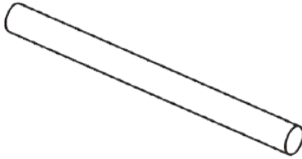
Part list

| | | | |
|---|---|--|---|
| 1 - Top Tray (x1) | 2 - Bottom Tray (x1) | 3 - Side Columns (2 x R / 2 x L) | 4 - Swivel Casters (x2) |
|  |  |  |  |
| 5 - Fixed Casters (x2) | 6 - M8 Bolts (x16) | 7 - 8mm Nuts (x16) | 8 - M6 Screws (x12) |
|  |  |  |  |
| 9 - Spring Washers (x16) | 10 - Handle (x1) | 11 - Hang Bar (x1) | 12 - M6 Screws (x4) |
|  |  |  |  |

Assembly Instructions

1.

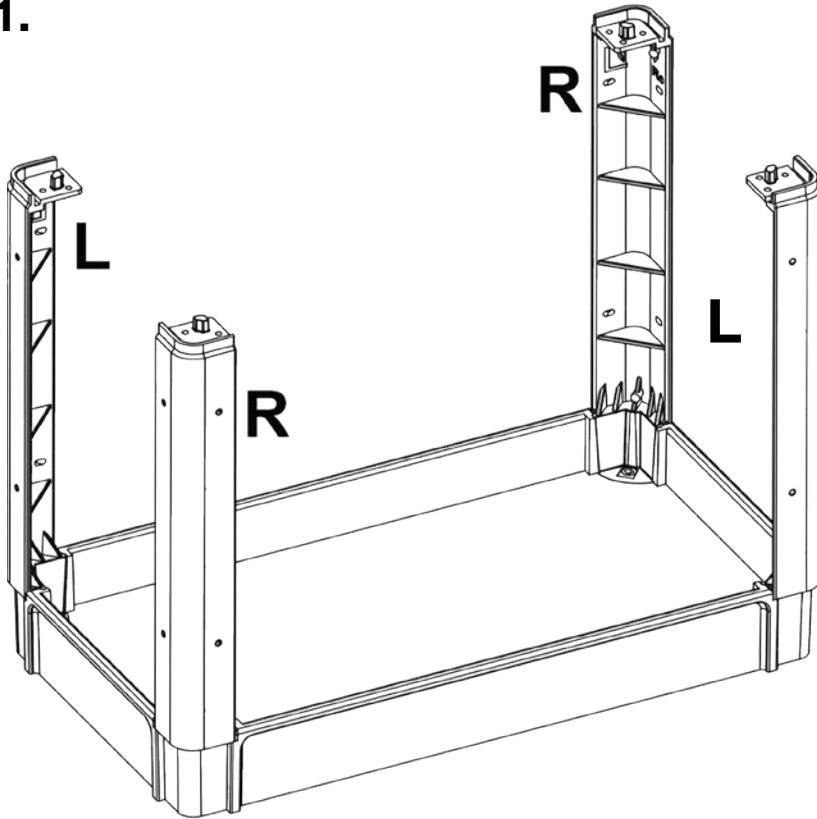

Insert side columns (3) into the bottom shelf (R to R, L to L). Side columns are marked.

2.

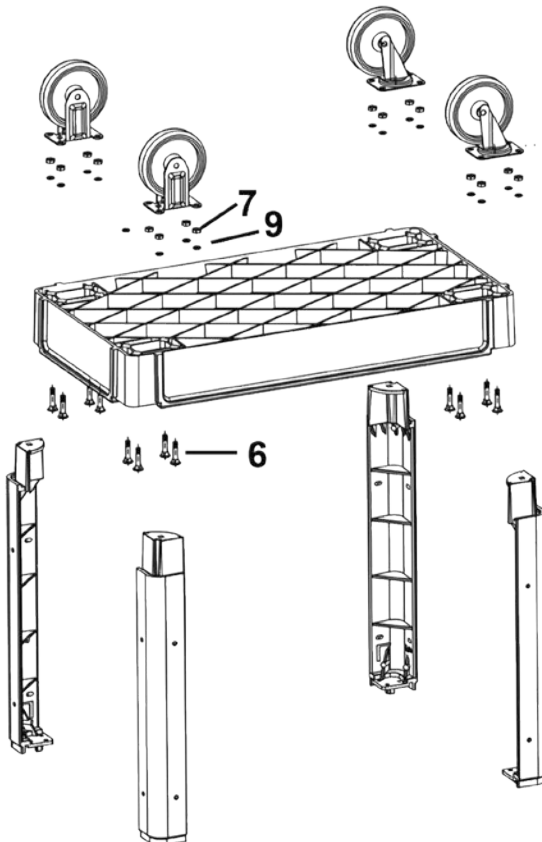

Install wheels (4+5) onto the bottom of the unit using bolts (6), washers (9), and nuts (7) as indicated on the diagram.

3.

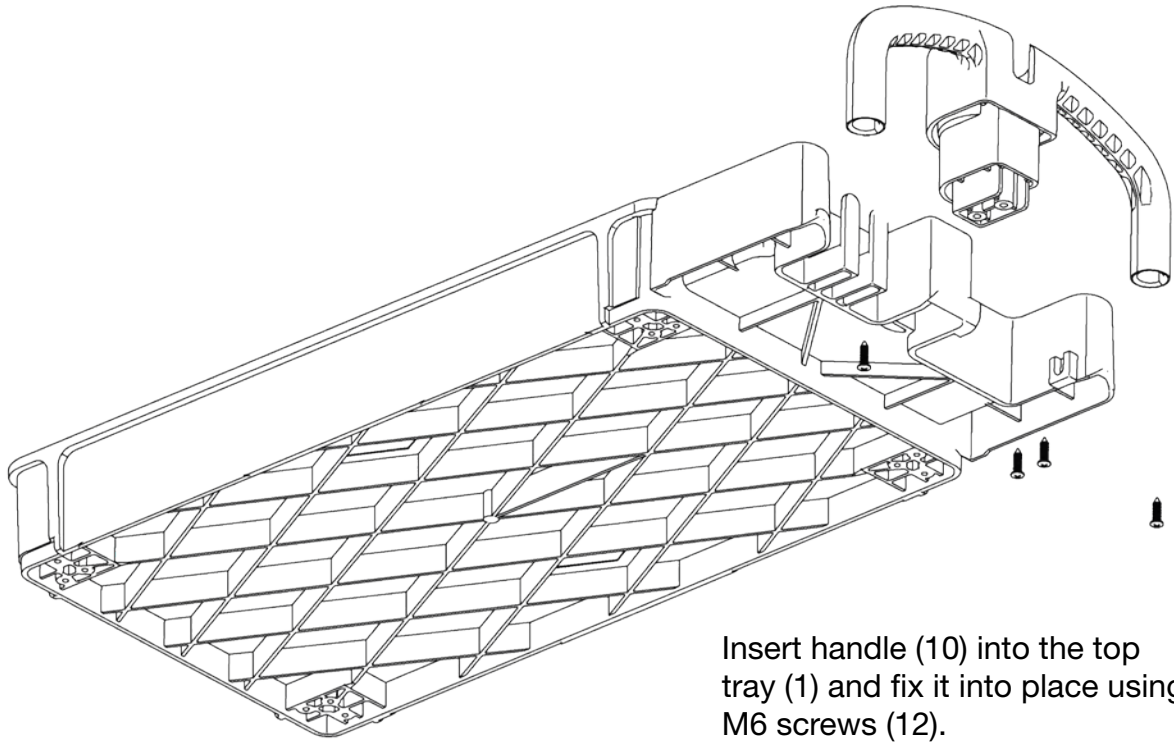

Insert handle (10) into the top tray (1) and fix it into place using M6 screws (12).

4.

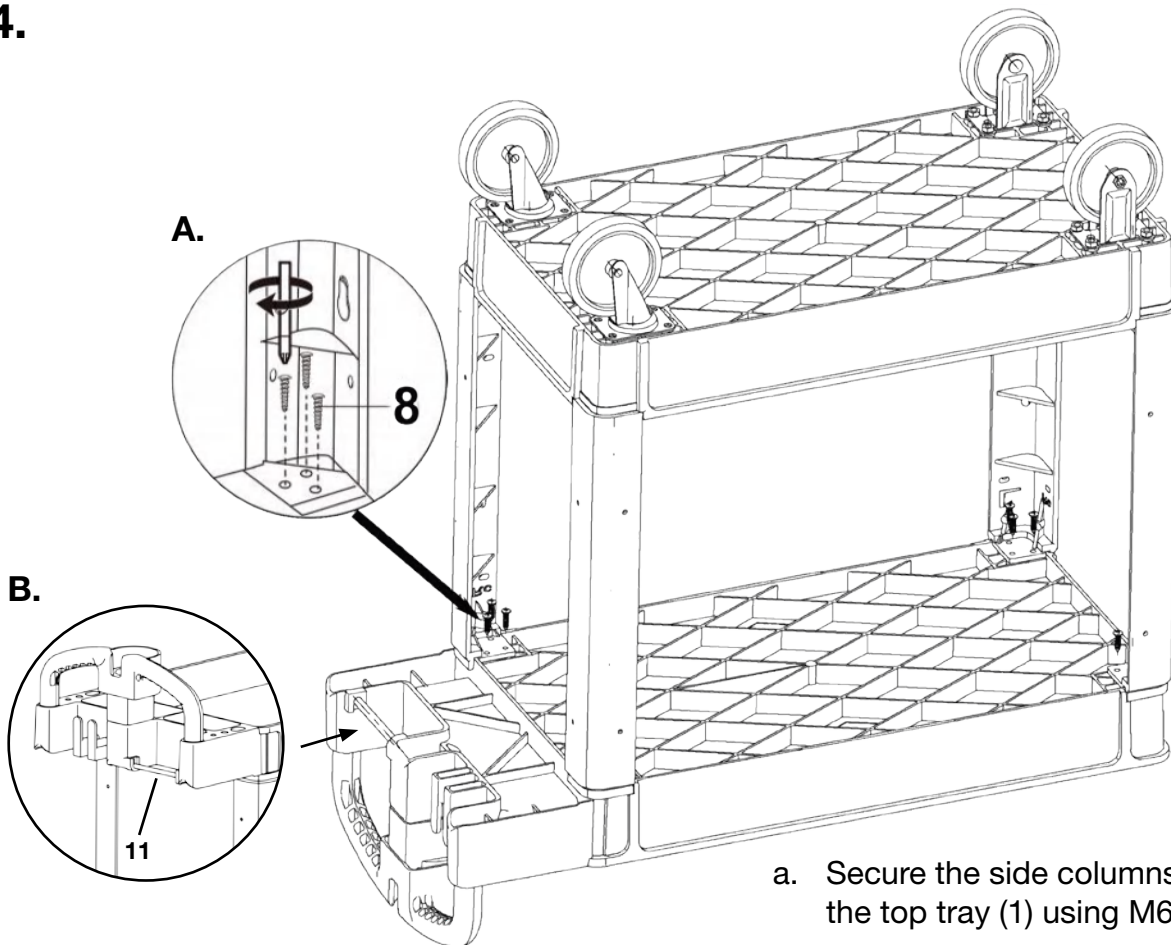

- a. Secure the side columns (3) with the top tray (1) using M6 screws (8).
- b. Insert Hang Bar (11) into slot on Handle (10) as shown on diagram.

Exploded Drawing

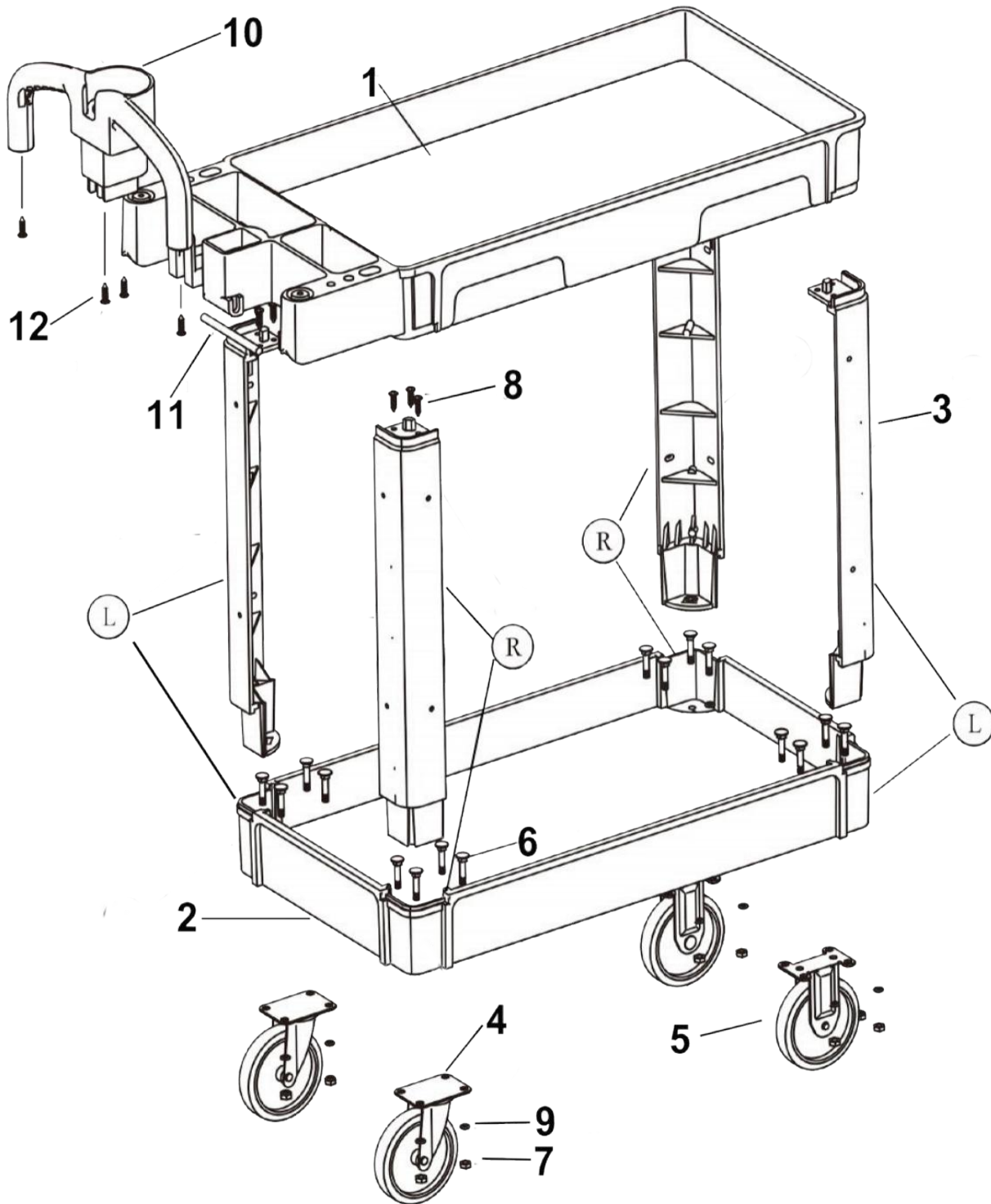

REPLACEMENT PARTS

| Model No. | Description | Parts |
|-----------|--|--------------------|
| MP998 | Fixed + Swivel Casters | 4 + 5 |
| MP999 | Hardware Pack | 6 + 7 + 8 + 9 + 12 |
| MQ093 | Replacement Ergonomic Handle for MQ092 | 10 |
| MQ094 | Replacement Hang Bar for MQ092 | 11 |
| MQ003 | Side Columns | 3 |