

# KLETON

## LOCKER, PERF. KD, FRONT & END BASE MODELS: FN824-FN825

### INSTRUCTIONS

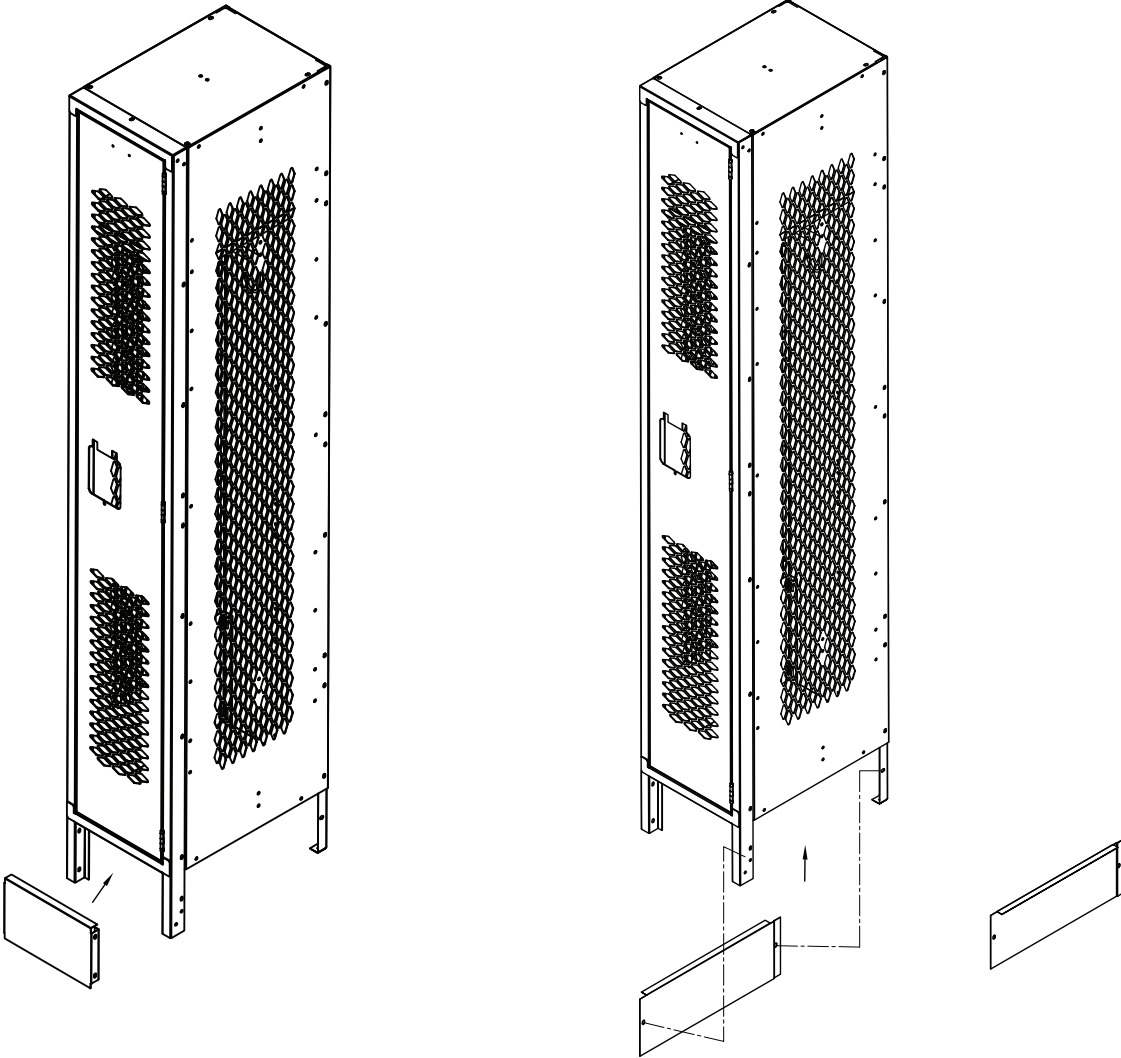

# INSTALLATION INSTRUCTIONS

## Front Base Installation

Position the front base between the front legs of the locker with the flange facing upward.

Secure the base to the locker using the provided #10-24 x 3/8" slotless screws and #10 nuts (provided).

Description	Qty
Front Base	1
#10 - 3/8" long slot less screws	4
#10 nuts	4

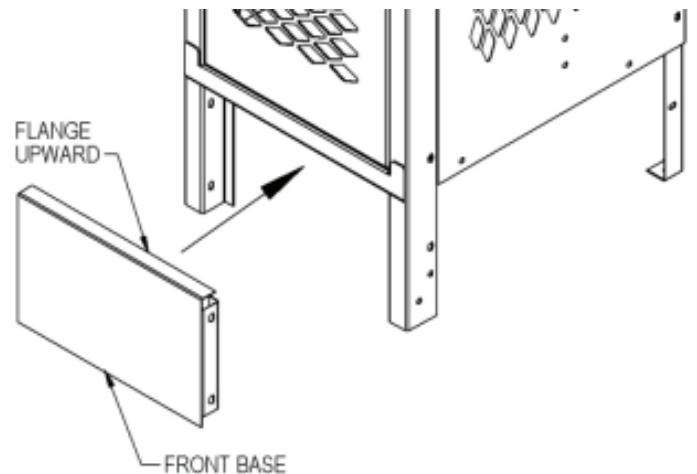

## End Base Installation

Position the left or right end base behind the corresponding side legs of the locker with the flange facing upward.

Fasten using the provided #10-24 x 3/8" slotless screws and #10 nuts.

Repeat for the other side.

Description	Qty
End Base	2
#10 - 3/8" long slot less screws	4
#10 nuts	4

