

# KLETON

**LOCKER, PERF.,KD,2&3 BANK, 2 TIER**  
**MODELS: FN822-FN823**

INSTRUCTIONS

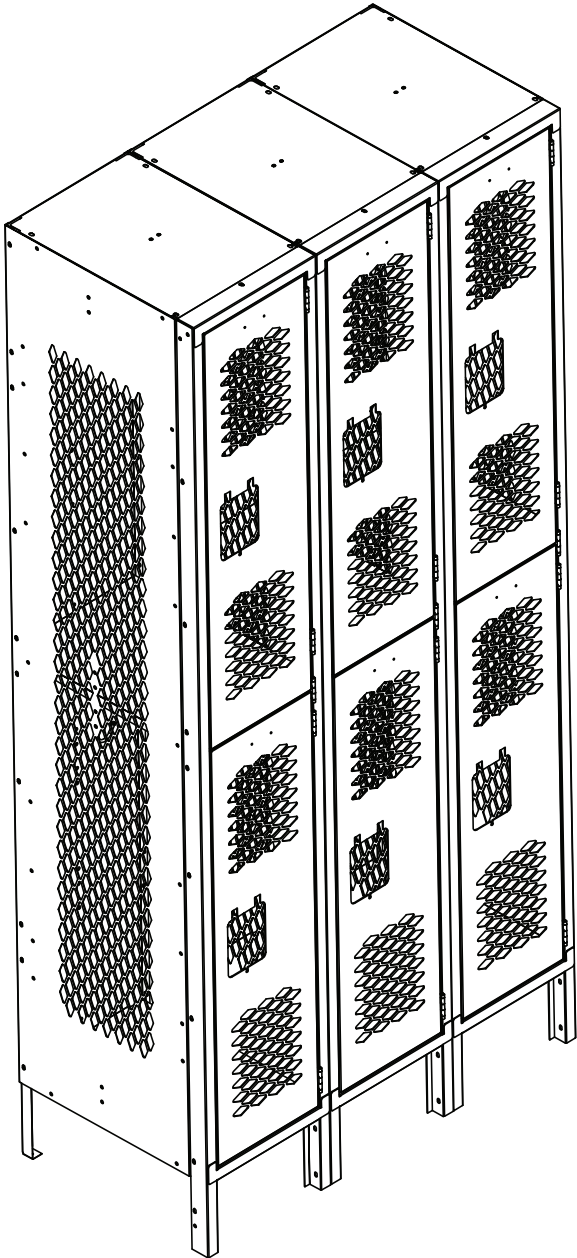

# PART LIST

Description	2 Bank	3 Bank
	Qty	Qty
Pre-assembled Door Frame	2	3
Top Shelf	2	3
Bottom Shelf	2	3
Compartment divider	2	3
Back Panel	2	3
Side Panel	3	4
Rear Leg	2	2
Double Coat Hook	4	6
Single Coat Hook	12	18
#10 - 3/8" long slot less screws	120	164
#10 nuts	120	164
Installation Instruction	2	2

# INSTALLATION INSTRUCTIONS

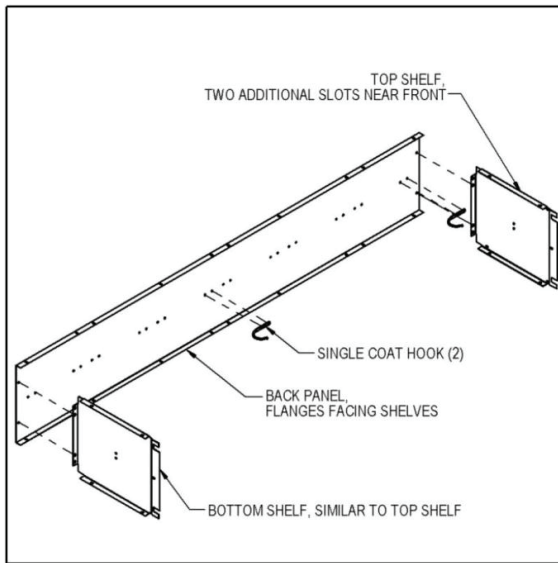

**Step 1:** Attach the top shelf, bottom shelf, and two single coat hooks to the back panel.

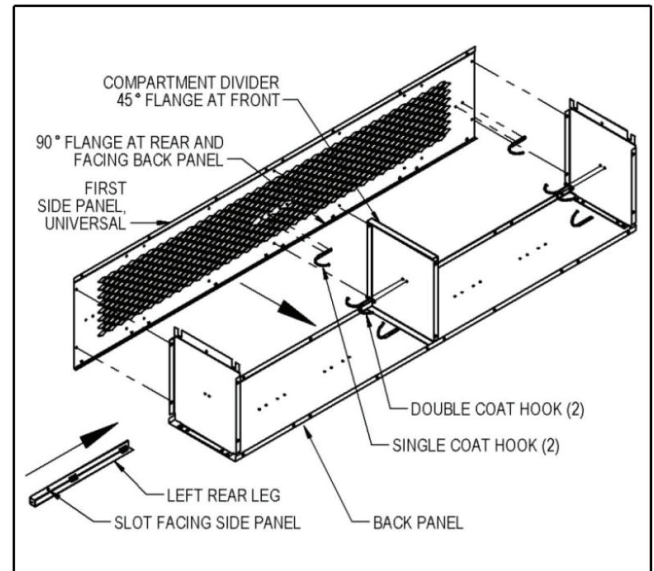

**Step 2:** Lay back panel flat with shelves up. Attach first side panel, left rear leg, and one compartment divider. Add two single coat hooks to side panel, one double coat hook under top shelf, and one under the divider.

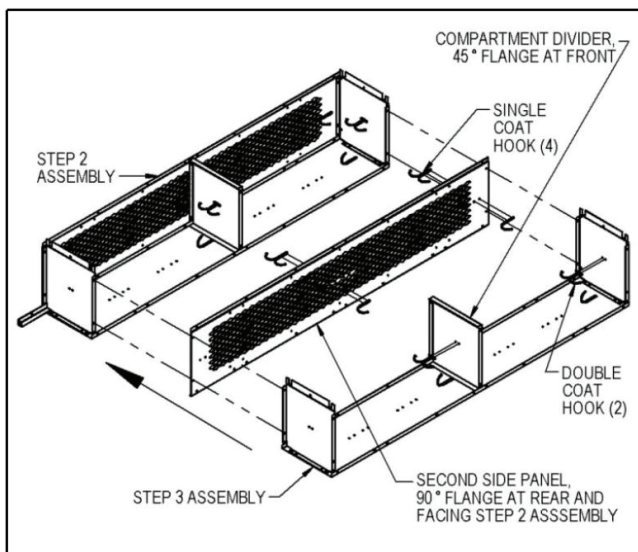

**Step 3:** Attach the second top shelf, the second bottom shelf, and an additional two single coat hooks to the second back panel as in step 1.

**Step 4:** Attach the second back panel assembly, second side panel, and one compartment divider to the previous assembly. Add two single coat hooks to each side of the second side panel and two double coat hooks to the assembly.

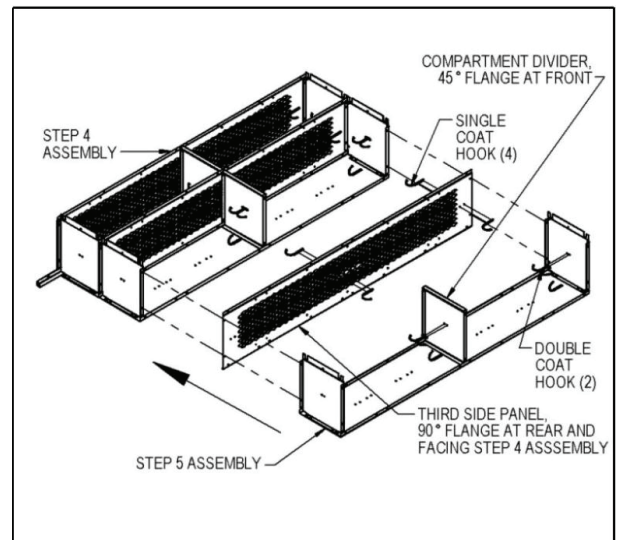

**Step 5:** Attach the third top shelf, the third bottom shelf, and an additional two coat hooks to the third back panel as in steps 1 and 3.

**Step 6:** Simultaneously attach the assembly of Step 5 (third Step 1 assembly), the third side panel, and one additional compartment divider to the assembly of Step 4. Attach two coat hooks to each side of the third side panel, and attach two double coat hooks to the assembly of step 5.

# INSTALLATION INSTRUCTIONS

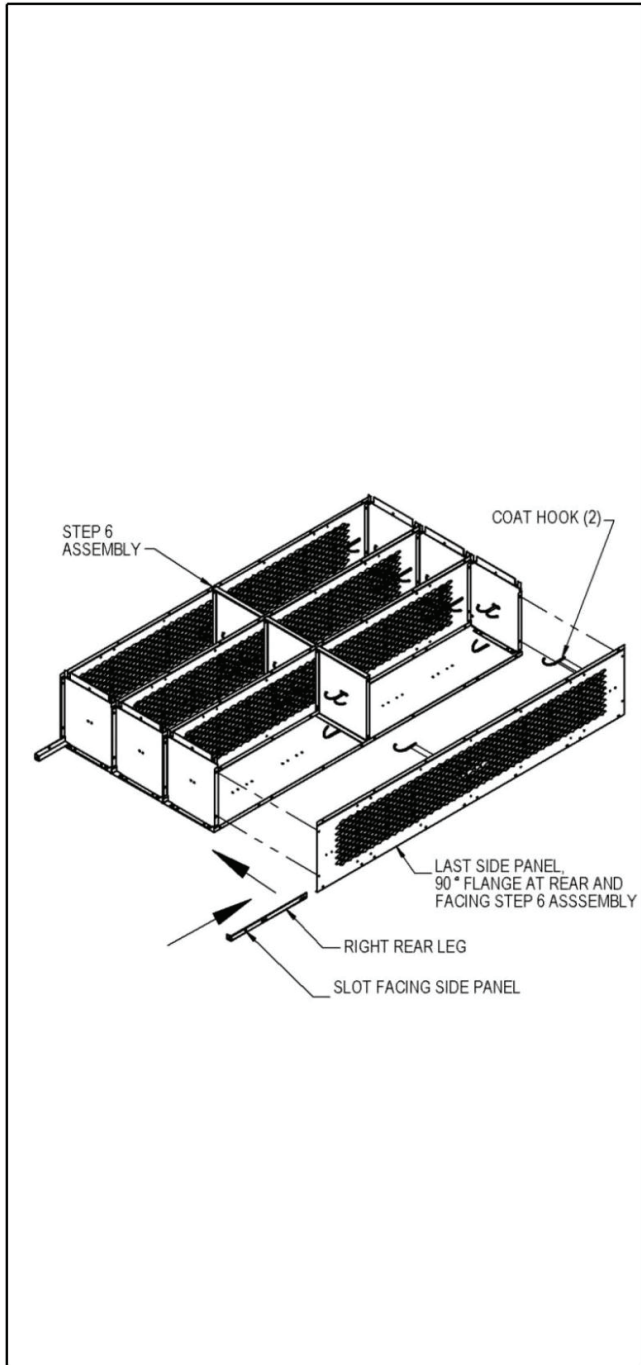

**Step 7:** Attach the last side panel and the right rear leg to the assembly of Step 6. Attach two additional single coat hooks to the last side panel. The locker chassis is now complete.

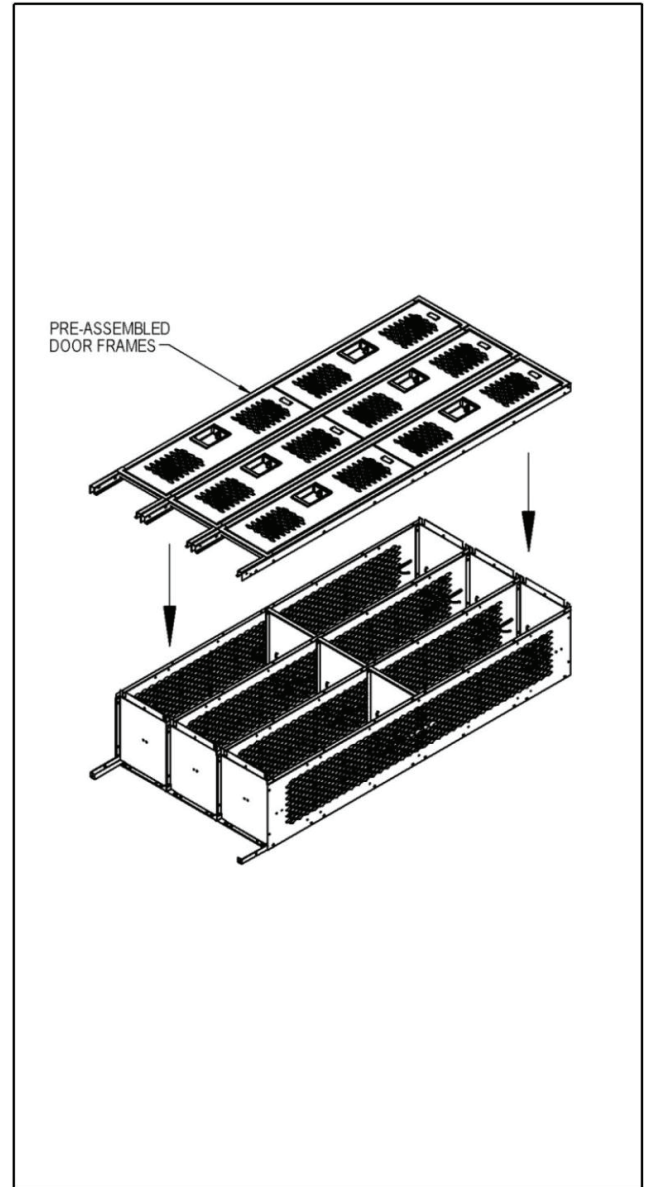

**Step 8:** Position the pre-assembled door frames onto the assembly of Step 7 then fasten one by one.

**Step 9:** Tighten all fasteners checking for squareness of the locker while tightening.

**Step 10:** Move locker into final position and anchor to floor, wall, or both (anchors not provided).

**Step 11:** Fasten all lockers in a row together by installing fasteners (provided) through the side panels. Installation is now complete.