

# KLETON

**LOCKER, PERF.,KD,1 BANK, 2 TIER**  
**MODELS: FN821**

INSTRUCTIONS

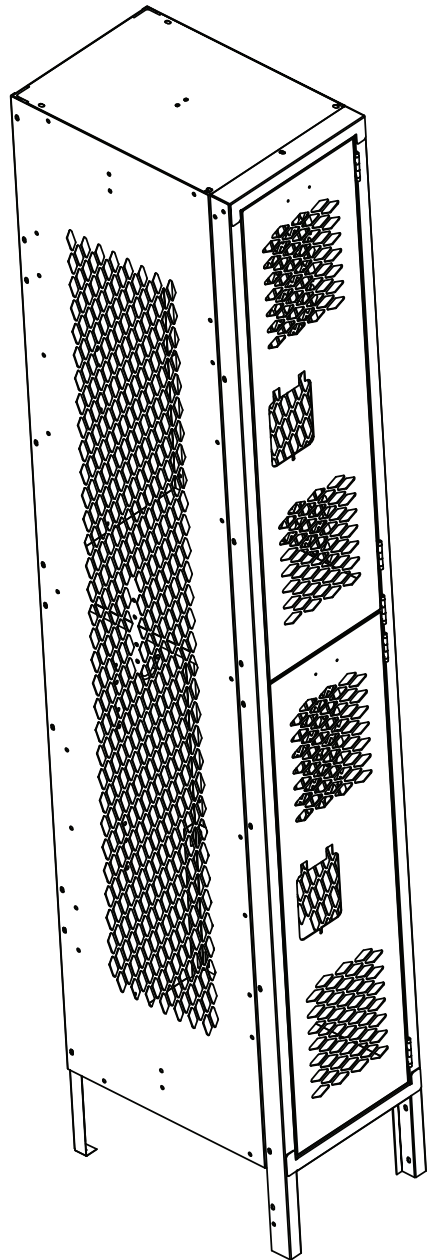

# PART LIST

Description	Qty
Pre-assembled Door Frame	1
Top Shelf	1
Bottom Shelf	1
Compartment divider	1
Back Panel	1
Side Panel	2
Rear Leg	2
Double Coat Hook	2
Single Coat Hook	6
#10 - 3/8" long slot less screws	76
#10 nuts	76
Installation Instruction	2

# INSTALLATION INSTRUCTIONS

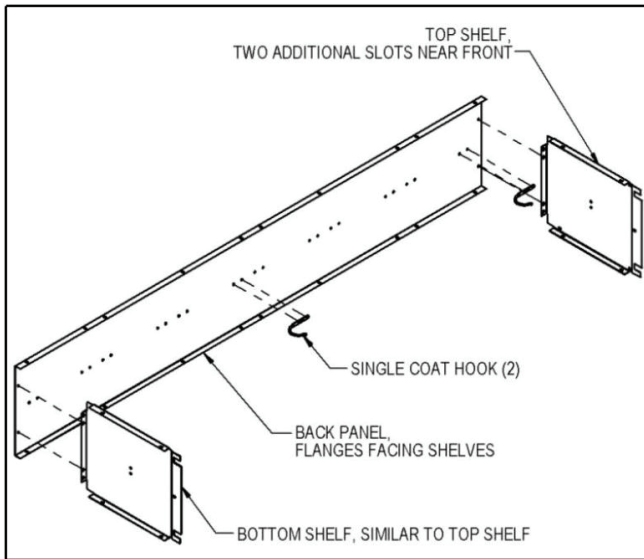

**Step 1:** Attach the top shelf, bottom shelf, and two single coat hooks to the back panel.

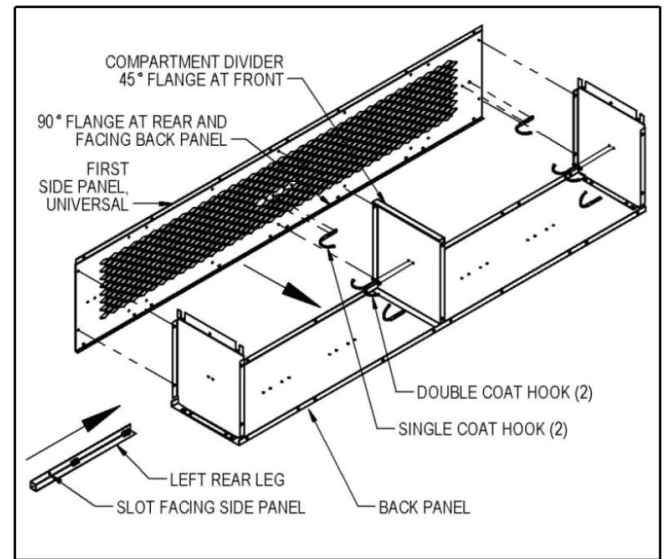

**Step 2:** Lay the back panel flat with shelves facing upward. Attach the first side panel, left rear leg, and the compartment divider. Then attach two single coat hooks to the side panel, one double coat hook beneath the top shelf, and another beneath the compartment divider.

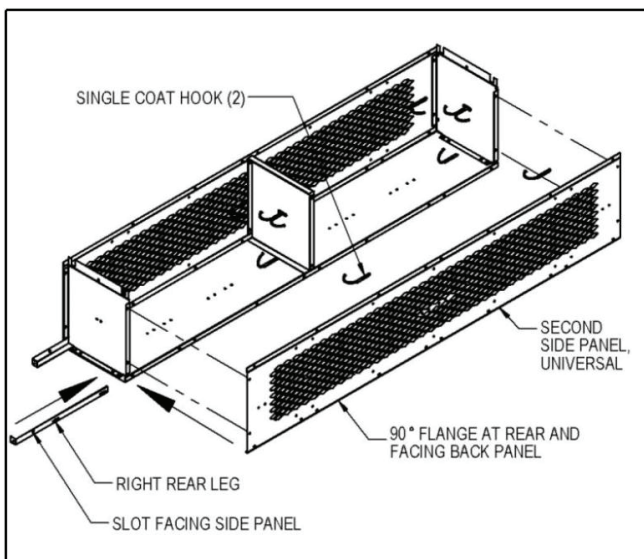

**Step 3:** Attach the second side panel and the right rear leg to the assembly of Step 2. Attach an additional two single coat hooks to the second side panel. The locker chassis is now complete.

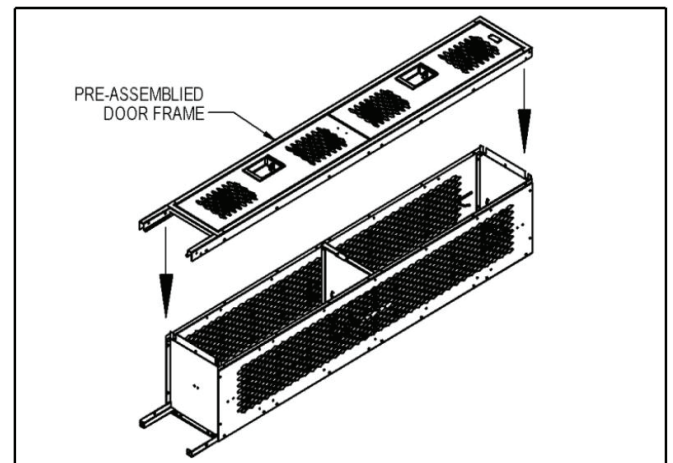

**Step 4:** Attach the pre-assembled door frame onto the assembly of Step 3.

**Step 5:** Tighten all fasteners checking for squareness of the locker while tightening.

**Step 6:** Position the locker in its final location and anchor it to the floor, wall, or both, as required (anchors not provided).

**Step 7:** Fasten all lockers in a row together by installing fasteners provided through the side panels. Installation is now complete.