

KLETON

LOCKER, PERF. KD, 2&3 BANK, 1 TIER
MODELS: FN819-FN820

INSTRUCTIONS

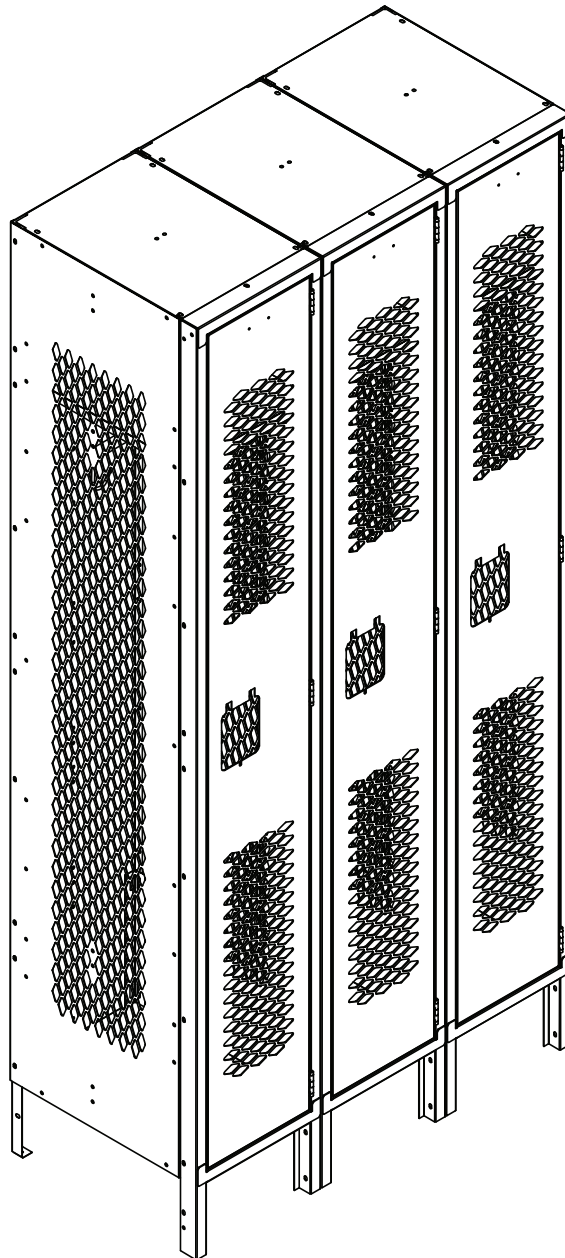

PART LIST

Description	2 Bank	3 Bank
	Qty	Qty
Pre-assembled Door Frame	2	3
Top Shelf	2	3
Bottom Shelf	2	3
Hat Shelf	2	3
Back Panel	2	3
Side Panel	3	4
Rear Leg	2	2
Coat Rod	2	3
Single Coat Hook	2	3
Single Coat Hook(With Double Bend)	4	6
#10 - 3/8" long slot less screws	102	139
#10 nuts	102	139
Installation Instruction	2	2

INSTALLATION INSTRUCTIONS

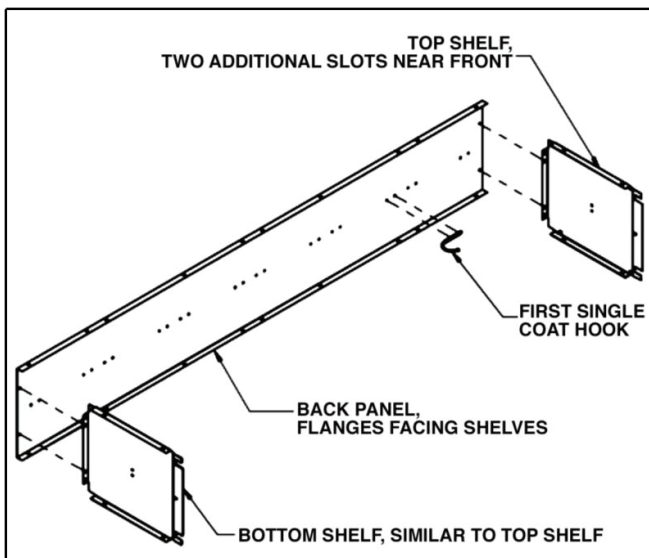

Step 1: Attach a top shelf, a bottom shelf, and the first single coat hook to a back panel.

Step 2: Turn the back panel on its back with the shelves pointing upward. Attach the first side panel, the left rear leg, and the first hat shelf to the assembly of Step 1. Attach a single coat hook with a double bend, this will accommodate the coat rod.

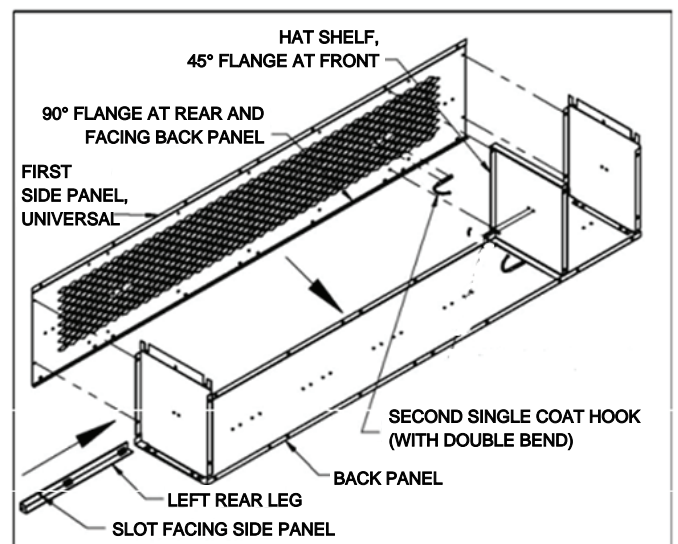

Step 3: Attach the second top shelf, the second bottom shelf, and an additional single coat hook to the second back panel as in step 1.

Step 4: Simultaneously attach the assembly of Step 3 (second Step 1 assembly), the second side panel, and the second hat shelf to the assembly of Step 2. Attach two additional single coat hooks with a double bend and install a coat rod as shown on last page.

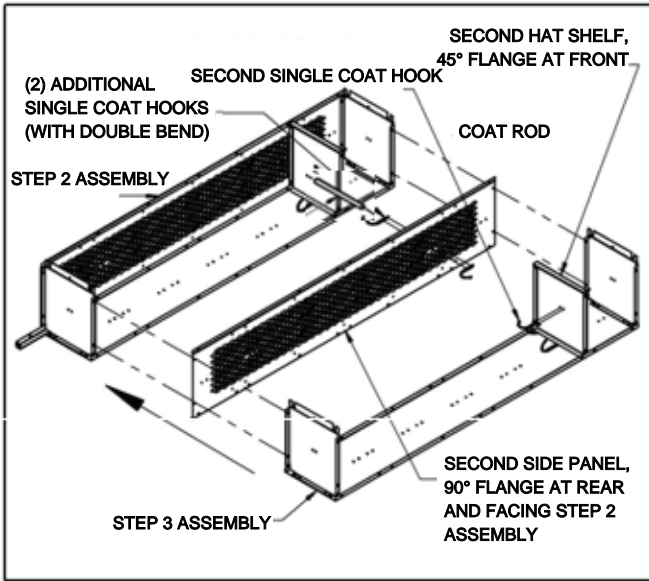

Step 5: Attach the third top shelf, the third bottom shelf, and an additional single coat hook to the third back panel as in steps 1 and 3.

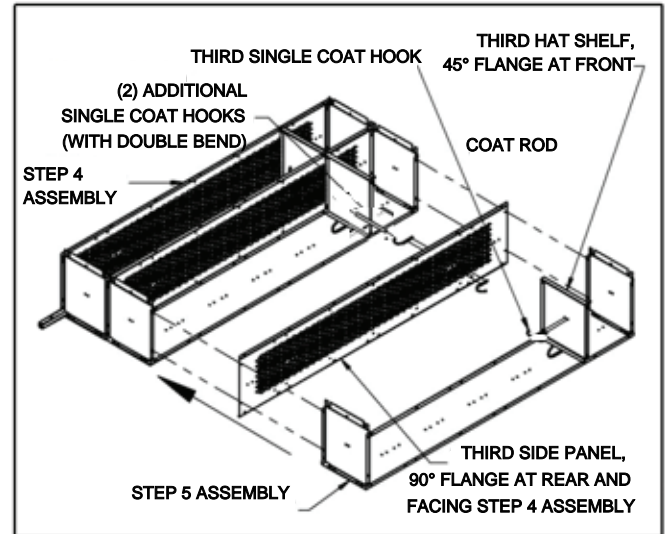

Step 6: Simultaneously attach the assembly of Step 5 (third Step 1 assembly), the third side panel, and the third hat shelf to the assembly of Step 4. Repeat the Step 4 coat hooks instructions to attach additional coat hooks and coat rods.

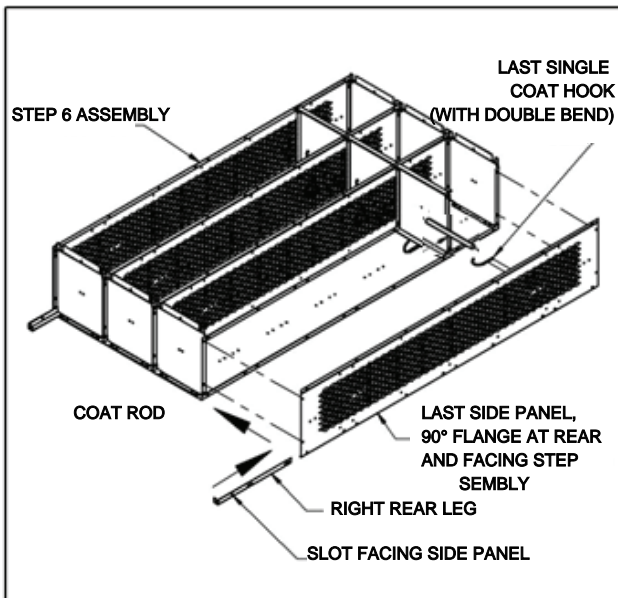

Step 7: Attach the last side panel and the right rear leg to the assembly of Step 6. Attach the final double-bend coat hook and install the last coat rod. The locker chassis is now complete.

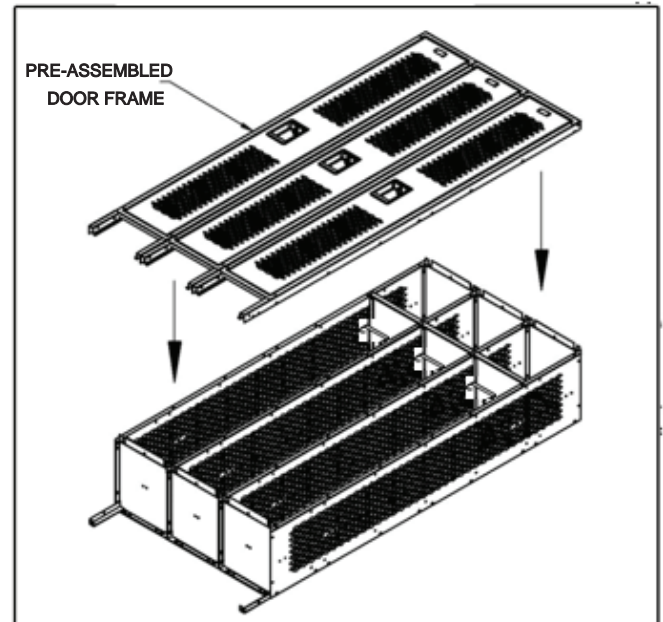

Step 8: Position the pre-assembled door frames onto the assembly of Step 7 then fasten one by one.

Step 9: Tighten all fasteners checking for squareness of the locker while tightening.

Step 10: Place the locker in the installed location and anchor to the floor, wall, or to both. Individual job conditions will dictate the type of fastening anchors to use (not provided).

Step 11: Fasten all lockers in a row together by installing fasteners (provided) through the side panels. Installation is now complete.

COAT ROD INSTALLATION

